

TORQSENSE®

RWT410/420 series Torque Transducer



Digital RWT410/420 series Torque Transducer

TorqSense Digital RWT410/420 series transducers with integral electronics now offer cost effective, non-contact digital rotary torque measurement, using Surface Acoustic Wave technology, suitable for torque monitoring, testing or controlling drive mechanisms. TorqSense RWT410/420 series transducers and their technology are particularly appropriate for OEM applications.

The new TorqSense RWT410/420 torque sensors replace the RWT310/320 series and feature all new electronics that have produced significant performance gains in resolution, frequency response, reduced sensor current consumption and faster digital data throughput. Transducer overload has also been increased to 300%.

Benefits

- Minimal shaft length
- High shaft stiffness
- Low inertia – High Speed capability because electronics are not fixed onto shaft
- Non contact/brushless measurement
- High bandwidth 10kHz
- 300% safe mechanical overload
- High accuracy (0.25%) and resolution (0.02%)
- Excellent noise immunity
- Integral digital electronics
- Operates both statically and dynamically
- clockwise/anti-clockwise
- Any full scale torque can be specified within standard range: 1Nm through to 13,000Nm
- Lifetime warranty



Consult factory for ranges greater than 13KNm
High speeds available on request

Technology

TorqSense patented technology is the measurement of the resonant frequency change in 'frequency dependent' Surface Acoustic Wave (SAW) devices, caused when strain is applied. The signal is coupled via a non-contact RF rotating couple from the shaft to a fixed pick-up.

Integral electronics enables the resonant frequencies to be measured and offer user selectable features, digital outputs and diagnostics. SAW devices are not affected by magnetic fields.

TorqSense RWT410 series transducers offer:

- Fixed voltage or current analog outputs (one for torque and the other for speed or power) for interfacing with analog instrumentation
- BIT Self-diagnostics for letting the manufacturer know that the transducer's torque, speed ratings and calibration due date have not been exceeded.
- Simple 'Sensor status' output pin
- Sensors to monitor shaft temperature for better compensation and accuracy

Whereas, TorqSense RWT420 series transducers offer:

- Digital outputs, such as RS232, CANbus and USB, for interfacing with modern instrumentation and laptops
- Digital input for configuring transducer via PC
- 2 x user selectable voltage or current analog outputs (one for torque and the other for speed, power or peak torque) for interfacing with analog instrumentation
- Transducer configuration software to allow user to changes transducer variables
- BIT Self-diagnostics for letting users know data is trustworthy, that the transducer's torque, speed ratings and calibration due date have not been exceeded
- Simple 'Sensor status' output pin
- Sensors to monitor shaft temperature for better compensation and accuracy
- Ability to connect up to 10 transducers using USB

TORQVIEW Software

TorqView is an easy to use advanced torque monitoring software, available to assist data recording and instrumentation displays that interface with Windows based PCs.

Features include: 3 types of display, text files compatible with Matlab and Excel and Real time chart plotting. See TorqView datasheet for more details.



LabView VIs are available for users to design their own process control applications. DLLs are also available for users to write their own custom software.

RWT410/420 Series Torque Transducers - Data Specification

Parameter	Condition	Data							Units			
RWT410/420 Torque measurement system												
Measurement method	Strain Dependent Surface Acoustic Wave Resonators (interrogated by an incremental electronic scanning method)											
Torque range	<i>(See Notes 1 & 2 below)</i>	0 – 1	0 – 1.1 to 0 - 20	0 – 21 to 0 - 100	0 – 101 to 0 - 500	0 - 501 to 0 - 2000	0 – 2001 to 0 - 13000	Nm				
		[0 - 10]	[0 - 11 to 0 - 200]	[0 - 201 to 0 - 1000]	[0 - 1001 to 0 - 5000]	[0 - 5001 to 0 - 20000]	[0 - 20001 to 0 - 175000]	[lbf in]				
Shaft size (diameter)		6	12	20	30	50	75	mm				
Rotation speed/angle of rotation measurement system												
Measurement method	Opto switch through slotted disc											
Direct output signal	Pulse output direct from opto switch (TTL, 5V square wave), output is independent of any analog or digital processing.											
Digital Processing Techniques	Processing Method		Update rate for analog and digital outputs									
	Mode 1 (Slow Method) Frequency Count		1							Hz		
	Mode 2 (Fast Method) Period Count		0 – 2000 RPM 2000 – 4000 RPM 4000 – 8000 RPM 8000 – 16000 RPM 16000 – 32000 RPM			RPM / 2 ((RPM – 2000) x 0.3227) + 650 ((RPM – 4000) x 0.196) + 800 ((RPM – 8000) x 0.1117) + 850 ((RPM – 16000) x 0.058) + 900				Hz		
Rotational speed (max)	<i>(See Note 3)</i>	30,000	20,000	15,000	12,000	9,000	6,000	RPM				
Temperature												
Measurement method	IR temperature sensor monitoring actual shaft temperature											
Temperature accuracy	±1										°C	
Reference temperature, T _{RT}	20										°C	
Operating range, ΔT _O	-10 to +50										°C	
Storage range, ΔT _S	-20 to +70										°C	
Temperature drift (FS)	Max	0.05										%FS/°C
Specifications												
Linearity	±0.25 (±0.5 for 2.5Nm and below)										%FS	
Hysteresis	<0.3										%FS	
Resolution	0.02										%FS	
Repeatability	0.1										%FS	
RWT410 Series Transducers ONLY												
Frequency response	560										Hz	
Accuracy	20°C, SM <i>(See Note 4)</i>	±0.25 (±0.5 for 2.5Nm and below)										%FS
RWT420 Series Transducers ONLY												
Frequency response		10,000	4500	2250	1125	562	281	140	70	Hz		
Accuracy	20°C, SM <i>(See Note 4)</i>	±1	±0.7	±0.5	±0.4	±0.25	±0.25	±0.25	±0.25	%FS		
Digital averaging	<i>(See Note 5)</i>	1	2	4	8	16	32	64	128	N		
Analog output												
Output voltages (Torque/Speed/Power)	Options available: ±1 / ±5 / ±10 / Unipolar (RWT410 Series default setting is ±5Vdc) (RWT420 Series output voltages are user selectable)										Vdc	
Load impedance	Maximum 1										KΩ	
Output currents (Torque/Speed/Power)	Options available: 4-20 / 0-20 / 12±8 (RWT420 Series output currents are user selectable)										mA	
4-20mA Loop resistance	Should not exceed 400										Ω	
Digital output (RWT420 Series Transducers ONLY)												
Output type (Normal)	RS232 throughput TBC				USB throughput TBC			CAN throughput TBC				
Output type (Bulk)	RS232 throughput TBC				USB throughput TBC			CAN throughput TBC				
Sampling rate	10										KHz	
Power supply												
Nominal voltage, V _S	12 to 32 (max)										V	
Current consumption, I _S	230 (max) @ 12 VDC										mA	
Power consumption, W _S	3										W	
Allowed residual ripple of supply voltage, V _{ripple}	500 (above nominal supply voltage)										mVp-p	
Electromagnetic compatibility												
EMC compatibility	EN 61326:2006											

Note 1. Any torque/FSD is possible between ranges – please specify max rated torque.

Note 2. Max rated torque should not be exceeded.

Note 3. Please consult factory for applications requiring rotational speeds that exceed maximum figures given. Transducers fitted for IP65 will have running speeds considerably reduced, increased drag torque and accuracy can be affected.

Note 4. SM – Static Mode. Dynamic values will depend upon user application and has to be adjusted accordingly.

Note 5. Digital averaging can be configured by user to optimise accuracy/frequency response for specific user applications. Digital averaging default setting is N=16. For details see User Manual.

Data parameters measured at +20°C

Sensor Technology Ltd reserves the right to change specification and dimensions without notice.

RWT410/420 Series Torque Transducers

Dimensions (1Nm to 100Nm)

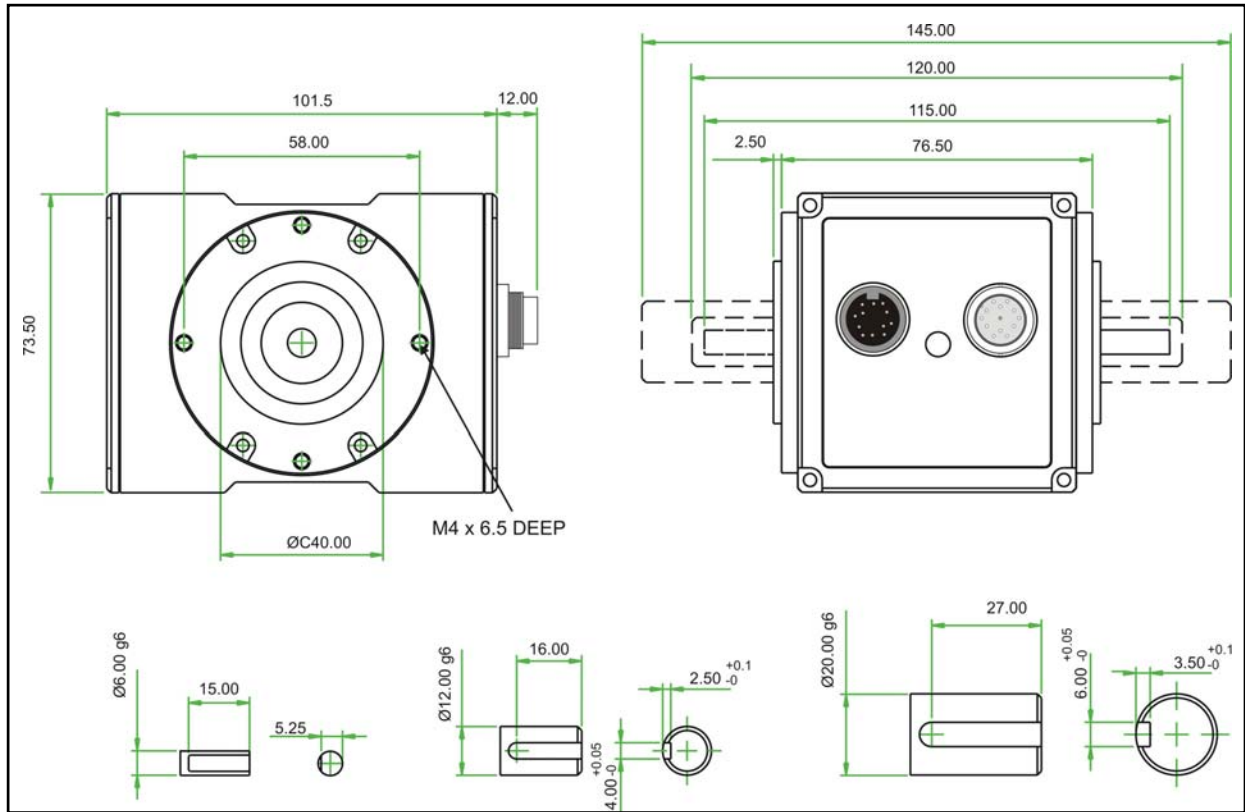

Parameter	Data												Units
Mechanical Properties													
Torque (Max)	1	2.5	3.9	6	8.5	13	17.5	20	30	55	85	100	Nm
Shaft Code	CF	DA	DF	DB	DC	DG	DD	DE	EB	EC	ED	EE	
Shaft Size (Diameter)	6	12						20					mm
Torsional Stiffness	0.23	1.28	1.3	1.32	1.6	1.7	1.8	1.9	4.1	6.4	8.1	9.2	KNm/rad
Mass moment of inertia, L_v	0.45	5.96	6.00	6.04	6.13	6.18	6.24	6.42	22.9	23.9	25.4	27.2	$\times 10^{-6}$ kg m ²
Max measurable load limit	120 (of rated torque)												%
Static safe load breaking	300 (of rated torque)												%
Shaft weight, approx	0.03	0.14	0.14	0.14	0.14	0.15	0.15	0.15	0.36	0.37	0.40	0.41	kg
Transducer with shaft weight, approx	0.7	0.8	0.8	0.8	0.8	0.8	0.8	0.8	1.0	1.0	1.1	1.1	kg

Data parameters measured at +20°C
 Sensor Technology Ltd reserves the right to change specification and dimensions without notice.

RWT410/420 Series Torque Transducers

Dimensions (101Nm to 500Nm)

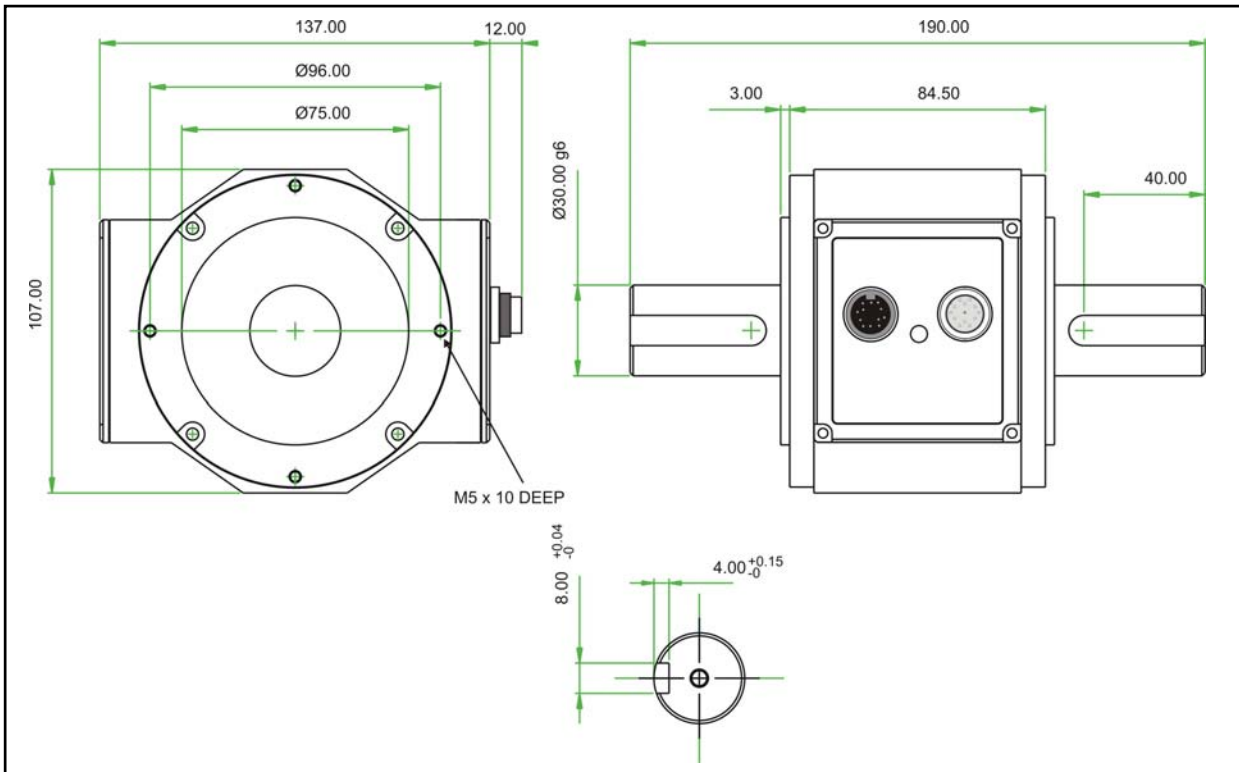

Parameter	Data					Units
Mechanical Properties						
Torque (Max)	175	225	265	350	500	Nm
Shaft Code	FA	FB	FC	FD	FE	
Shaft Size (Diameter)	30					mm
Torsional stiffness	32.9	35.6	37.2	37.9	39.8	kNm/rad
Mass moment of inertia	138.9	143.1	147.7	151.9	174.2	$\times 10^{-6} \text{ kg m}^2$
Max measurable load limit	120 (of rated torque)					%
Static safe load breaking	300 (of rated torque)					%
Shaft weight, approx	1.1	1.1	1.1	1.2	1.2	kg
Transducer with shaft weight, approx	2.4	2.4	2.4	2.5	2.5	kg

*Data parameters measured at +20°C
Sensor Technology Ltd reserves the right to change specification and dimensions without notice.*

RWT410/420 Series Torque Transducers

Dimensions (501Nm to 13000Nm)

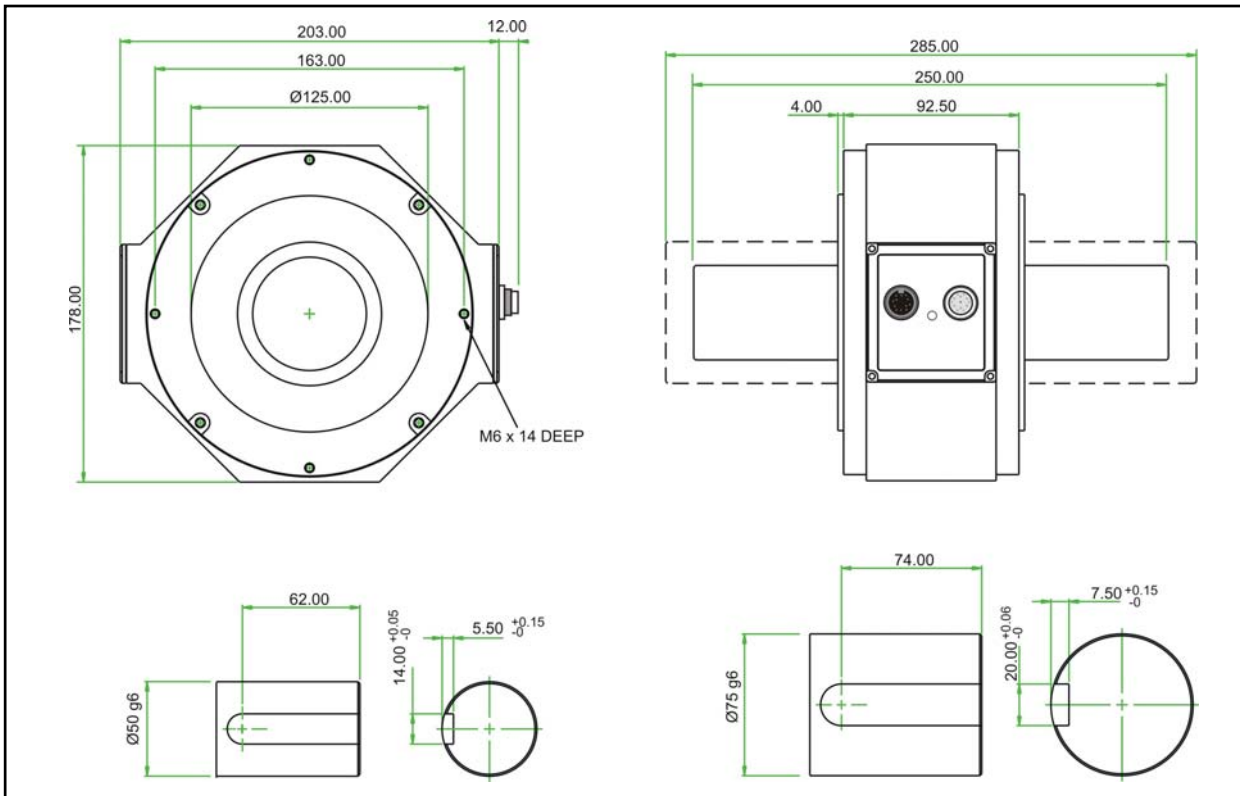

Parameter	Data										Units
Mechanical Properties											
Torque (Max)	650	850	1100	1350	2000	3000	4000	6000	10000	13000	Nm
Shaft Code	GE	GA	GB	GC	GD	HA	HB	HC	HF	HG	
Shaft Size (Diameter)	50					75					mm
Torsional Stiffness	TBC	TBC	199.2	TBC	214.1	TBC	TBC	914.4	945.5	TBC	kNm/rad
Mass moment of inertia	TBC	TBC	1330	TBC	1497	TBC	TBC	7932.7	9407.1	TBC	$\times 10^{-6}$ kg m ²
Max measurable load limit	120 (of rated torque)										%
Static safe load breaking	300 (of rated torque)										%
Shaft weight, approx	TBC	TBC	3.9	TBC	4.1	TBC	TBC	10.2	10.6	11.2	kg
Transducer with shaft weight, approx	TBC	TBC	7.1	TBC	7.3	TBC	TBC	13.4	13.8	14.4	kg

Data parameters measured at +20°C
 Sensor Technology Ltd reserves the right to change specification and dimensions without notice.

RWT410/420 Series Torque Transducers - Standard Range

● – Standard feature ◇ – Optional feature

	RWT410/420 Series		Option Code	Remarks
	RWT410	RWT420		
Torque, Speed, Power Outputs				
Torque only	410	420		
Torque & Speed (60 pulses/rev)	411			User to specify RPM/FSD when ordering
Torque & Speed (360 pulses/rev)	412			Not yet available
Torque & Power (60 pulses/rev)	413			User to specify Power/FSD when ordering
Torque & Speed (60 pulses/rev) or Power		421		Outputs are user selectable
Torque & Speed (360 pulses/rev) or Power		422		Not yet available
Standard features				
Keyed Shaft Ends	●	●	K	1Nm will have flats
Voltage output $\pm 5v$ FSD (Fixed)	●		B	
Voltage outputs from $\pm 1v$ to $\pm 10v$ FSD and unipolar (Variable)		●		Output is user selectable
RS232 output		●		
Torque Averaging and Torque Peak		●		
Self Diagnostics	●	●		
Internal temperature measurement	●	●		Value available on RWT420 series only
Deep grooved shielded bearings with oil lubrication	●	●		
Ingress Protection (IP) 54	●	●		
Optional features				
Plain Shaft Ends	◇	◇	P	Shaft length will be longer than keyed end shafts – consult factory for length
Voltage output $\pm 1v$ FSD (Fixed)	◇		A	In place of Option B
Voltage output $\pm 10v$ FSD (Fixed)	◇		C	In place of Option B
Unipolar voltages (Fixed)	◇		U	In place of Option B. User to specify range/scale when ordering
Current output 0-20mA (Fixed)	◇		D	In place of Voltage output options
Current output 4-20mA (Fixed)	◇		E	In place of Voltage output options
Current output $12\pm 8mA$ (Fixed)	◇		V	In place of Voltage output options
Current output 0-20mA, 4-20mA & $12\pm 8mA$ (Variable)		◇	F	Current output is user selectable and in place of Voltage output. However user can reselect a Voltage output, if required. (Note 6)
USB 2.0 full speed 12 Mbps Digital output		◇	G	
CANbus output		◇	H	In place of RS232 output
High Speed Bearings (See Note 7 below)	◇	◇	J	Consult factory for maximum speed allowance.
Sealed Bearings	◇	◇	S	
Ingress Protection (IP) 65 (See Note 8 below)	◇	◇	L	

Note 6. 2 x analog channels available. Default settings are Channel 1 (voltage/current) – torque. Channel 2 (voltage/current) – speed or power, if ordered.

Note 7. At very high speeds, for better balance the factory recommend plain or splined shafts.

Note 8. Transducers fitted for IP65 will have running speeds considerably reduced, increased drag torque and accuracy can be affected.

Data parameters measured at $+20^{\circ}C$

Sensor Technology Ltd reserves the right to change specification and dimensions without notice.

RWT410/420 Series Torque Transducers – Connector and Lead Options

	RWT410/420 Series		Option Code	Remarks/Purpose
	RWT410	RWT420		
Connectors & Leads				
Analog Connector <i>12 Pin Lumberg (female)</i>	◇	◇	ACC 1	<i>For user to self wire</i>
Digital Connector <i>12 Pin Lumberg (male)</i>		◇	ACC 2	<i>For user to self wire</i>
Analog Lead (Length 2.5m) <i>12 Pin Lumberg (female) to 15 way 'D' type connector (female)</i>	◇	◇	ACC 3	<i>For connecting RWT to user's system via 15 pin 'D' connector</i>
Digital Lead (Length 2.5m) <i>12 Pin Lumberg (male) to 15 way 'D' type connector (male)</i>		◇	ACC 4	<i>For connecting RWT to user's system via 15 pin 'D' connector</i>
Digital Lead Adapter (Length 1m) <i>15 Way 'D' type (female) to RS232 and Power Connectors</i>		◇	ACC 5	<i>For connecting RWT to PC via RS232</i> <i>[Also needs Digital Lead (ACC4) to connect to RWT]</i>
Digital Lead Adapter (Length 1m) <i>15 Way 'D' type (female) to RS232, USB and Power Connectors</i>		◇	ACC 6	<i>For connecting RWT to PC via USB (Option G) or RS232</i> <i>[Also needs Digital Lead (ACC4) to connect to RWT]</i>
Digital Lead Adapter (Length 1m) <i>15 Way 'D' type (female) to CANbus and Power Connectors</i>		◇	ACC 8	<i>For connecting RWT to PC via CANbus (Option H)</i> <i>[Also needs Digital Lead (ACC4) to connect to RWT]</i>
Digital Lead Adapter (Length 1m) <i>15 Way 'D' type (female) to CANbus, USB and Power Connectors</i>		◇	ACC 9	<i>For connecting RWT to PC via USB (Option G) or CANbus (Option H)</i> <i>[Also needs Digital Lead (ACC4) to connect to RWT]</i>

RWT410/420 Series Torque Transducers – Additional related products

	Code	Remarks/Purpose
Transducer Display ETD	ETD	<i>Display readout</i>
AC Mains Adapter Power Supply	PSU 1	<i>For providing 12-32Vdc</i>
Transducer Signal Breakout Unit	SBU 1	
TorqView	TV	<i>Torque Monitoring Software</i>

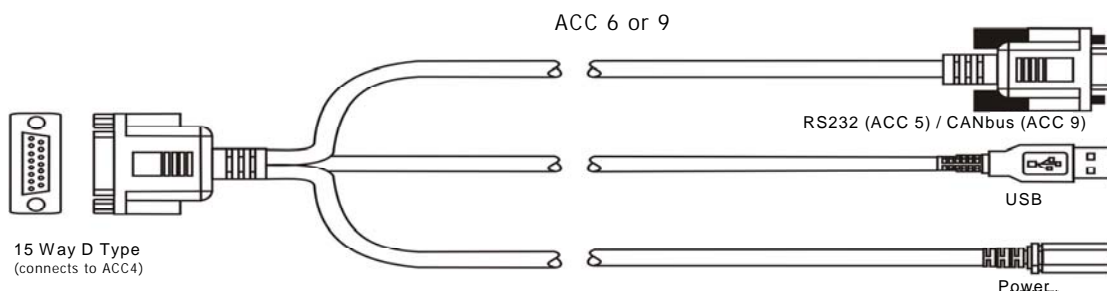
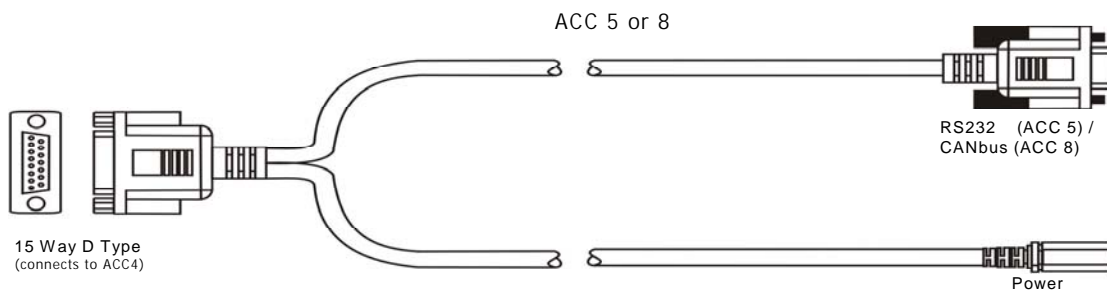
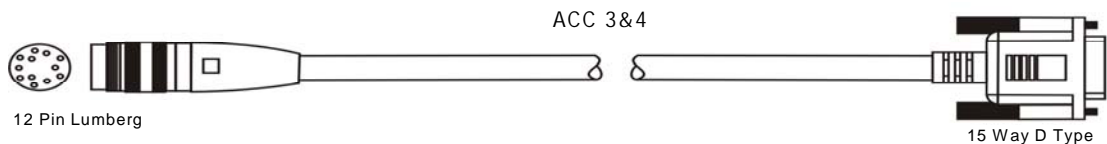

Data parameters measured at +20°C

Sensor Technology Ltd reserves the right to change specification and dimensions without notice.

When ordering a Torque Transducer please note that any torque/FSD is possible between ranges – please specify rated torque and options using the following format:

For example: RWT	411 - 15Nm -	K-CL	A 'basic' transducer with torque and speed outputs, rated and calibrated to 15Nm FSD with keyed ends, ±10v and IP65 protection.
Your transducer requirement: RWT			
Max speed (if applicable)		RPM	
Connector & Lead options		(if applicable) <i>See over</i>	
Additional related products		(if applicable) <i>See over</i>	

Glossary of terms and definitions used in this datasheet

- **Surface Acoustic Wave (SAW)** - An acoustic wave travelling along the surface of a material having some elasticity, with amplitude that typically decays exponentially with the depth of the substrate.
- **Strain dependent SAW resonators** – A type of elastic SAW device, which changes its resonant properties when it is subjected to axial strain/compression. TorqSense uses this principle, which is protected by a number of patents.
- **Incremental Electronic Scan (IES)** – The most successful and precise method for interrogating strain dependent SAW resonators. The IES interrogation method uses a processor controlled frequency synthesiser to excite the SAW resonators over a defined range of frequencies and measure the reflected signal. TorqSense uses this patented method.
- **Resolution of the IES method** - The minimum measurable number corresponding to the stress/strain sensitive resonance point of the SAW resonator. The value is limited by following the factors:
 - frequency resolution of the synthesiser, which is 1000 times greater than overall resolution of the system.
 - relationship between frequency response and resolution. Increments of the resolution will proportionally decrease the system's frequency response. TorqSense systems are optimised for the best performance that suits most applications. However, on the RWT420 series models customers do have the capability to adjust the system performance.
- **Frequency response of the IES method** – The measure of the TorqSense system's response at the output to a signal of varying frequency at its input. The frequency response is typically characterised by the magnitude of the system's response, measured in dB. There are two ways of characterising the system's frequency response:
 - 0.1dB frequency range, where the output magnitude of the signal is different to the input magnitude of the signal by not more than 0.1dB (practically absolutely identical).
 - 3dB frequency range, where the output magnitude of the signal is 0.707 of the input signal. This is a common standard for most applications, unless it specifically says otherwise. This standard is also used to characterise the TorqSense system's frequency response.
- **Accuracy** - The degree of conformity of a measured or calculated quantity, which will show the same or similar results. Accuracy of the overall TorqSense system is limited by the combined error of several factors such as linearity, hysteresis, temperature drifts and other parameters affecting measurements. If errors in the system are known or can be estimated, an overall error or uncertainty of measurement can be calculated.
- **Digital averaging** – The application of algorithms to reduce white noise. In any electronic system, electronic white noise is mixed with the signal and this noise usually limits the accuracy. To reduce the influence of white noise and increase the accuracy of the system different averaging algorithms can be applied. In the TorqSense system a flying digital averaging technique is applied to reduce the white noise commensurate with the level of accuracy required. However, as any averaging algorithm works as a low pass filter, the more averaging that is applied the lower the frequency response. Therefore, each TorqSense system should be optimised to the customer's requirements by choosing the right combination of accuracy/frequency response. Please see relevant part of the Datasheet and User Manual.

Data parameters measured at +20°C

Sensor Technology Ltd reserves the right to change specification and dimensions without notice.